

Technical Information

- CV** Check Valves
- SH** Shuttle Valves
- LM** Load/Motor Controls
- FC** Flow Controls
- PC** Pressure Controls
- LE** Logic Elements
- DC** Directional Controls
- MV** Manual Valves
- SV** Solenoid Valves
- PV** Proportional Valves
- CE** Coils & Electronics
- BC** Bodies & Cavities
- TD** Technical Data

General Description

Threaded Cartridge Style Counterbalance Valve. Pilot assisted, designed for motion control applications. For additional information see Technical Tips on pages LM1-LM4.

Features

- High flow design with extra dampening
- Spring chamber isolated from system backpressure by double seal, eliminating vent port leakage and need for separate drain line
- Poppet construction for minimal leakage
- Incorporates direct acting relief valve for overload protection
- Includes reverse check valve within body, saving space and minimizing installation cost
- Hardened working parts for maximum durability
- Adjustable and tamper resistant versions available
- All external parts zinc plated

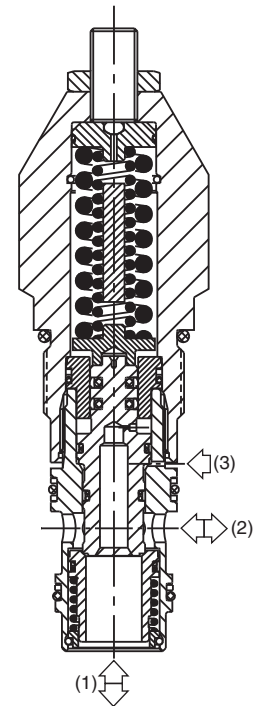
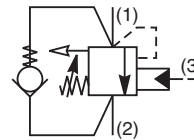
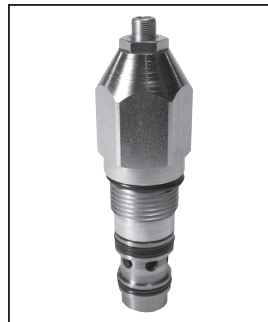

Specifications

Rated Flow	180 LPM (48 GPM)
Pressure	50 - 350 Bar (725 - 5000 PSI)
Sensitivity: Pressure/Turn	50 Bar (725 PSI)
Pilot Ratio	E6A060*409 - 8 : 1 E6B060*409 - 3 : 1
Cartridge Material	All parts steel. All operating parts hardened steel.
Operating Temp. Range/Seals	-34°C to +121°C (Nitrile) (-30°F to +250°F) -26°C to +204°C (Fluorocarbon) (-15°F to +400°F)
Fluid Compatibility/ Viscosity	Mineral-based or synthetic with lubricating properties at viscosities of 45 to 2000 SSU (6 to 420 cSt)
Filtration	ISO-4406 18/16/13, SAE Class 4
Approx. Weight	0.53 kg (1.17 lbs.)
Cavity	3C (See BC Section for more details)

Performance Curves

Relief & Pilot Performance 1 to 2

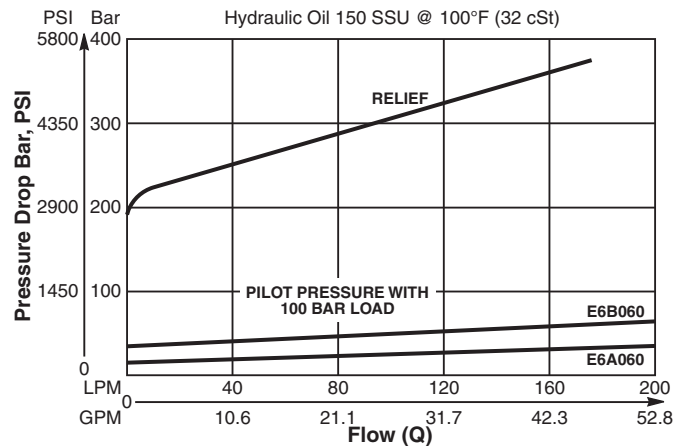

Pressure Drop vs Flow

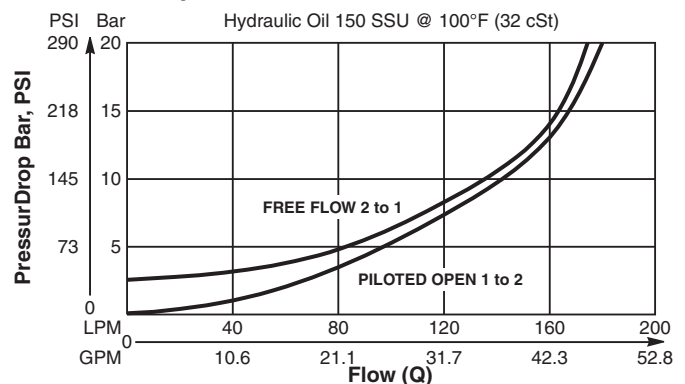

Dimensions Millimeters (Inches)

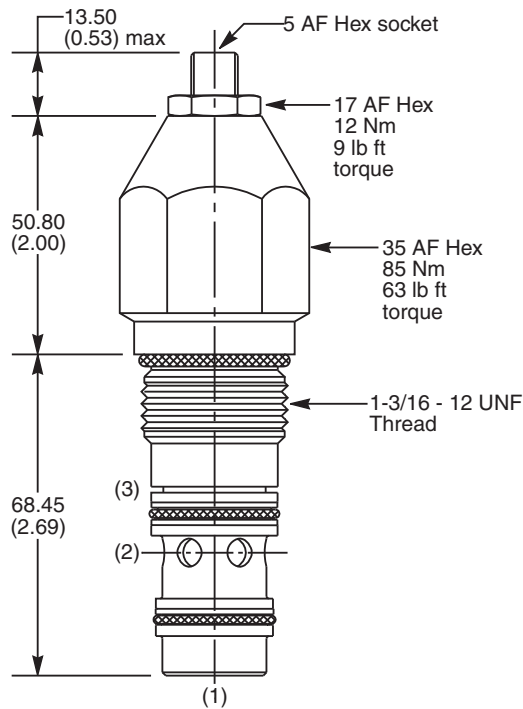

Ordering Information

E6		060				409
Load Control Valve	Pilot Ratio	Adjustment Style	Cracking Pressure	Seals	Suffix Number	

Code	Pilot Ratio
A	8 : 1
B	3 : 1

Code	Adjustment Style / Kit No.
Z	Screw Adjust (Standard)
T	Tamper Resistant (TC1125)

Code	Cracking Pressure
	Omit for no setting (Standard)* Specify setting if required

**Standard valve is set to crack at 215 Bar (3120 PSI). Valve to be set to 1.4 times maximum load induced pressure.*

Code	Seals / Kit No.
N	Nitrile, Buna-N (Std.) / (SK30008N-1)
V	Fluorocarbon / (SK30008V-1)

Code	Suffix Number
409	High flow design with extra dampening

Order Bodies Separately

LB10		
Line Body	Porting	Body Material

Code	Porting
069	1" SAE (main) 1/4" SAE (aux)
234	3/4" SAE Dual Cavity

Code	Body Material
A	Aluminum
S	Steel